

- ① HITCH ARM RIM ROLLER NO. - 2
- ② WHEEL HUBS (PACK BEARINGS) NO. - 8
- ③ WHEEL FRAME PIN NO. - 2
- ④ SCREED EXTENSION HOUSING NO. - 4
- ⑤ SCREED SCREW BEARING NO. - 2
- ⑥ PINION SHAFT BEARING NO. - 4
- ⑦ MAIN SHAFT BEARINGS NO. - 3
- ⑧ SCREED SCREW NUT NO. - 2
- ⑨ TRACK AXLE NO. - 6
- ⑩ SIDE ROLLS (SEE NOTE # 3) NO. - 2

NOTE:

1. TRACK PAVERS — 25 LUBRICATED POINTS.
2. RUBBER TIRED PAVERS — 29 LUBRICATED POINTS.
3. REF. NO. 10 — PLUG MUST BE REMOVED AND GREASE FITTING INSERTED FOR LUBRICATING SIDE ROLLS, PLUG IS THEN REPLACED.

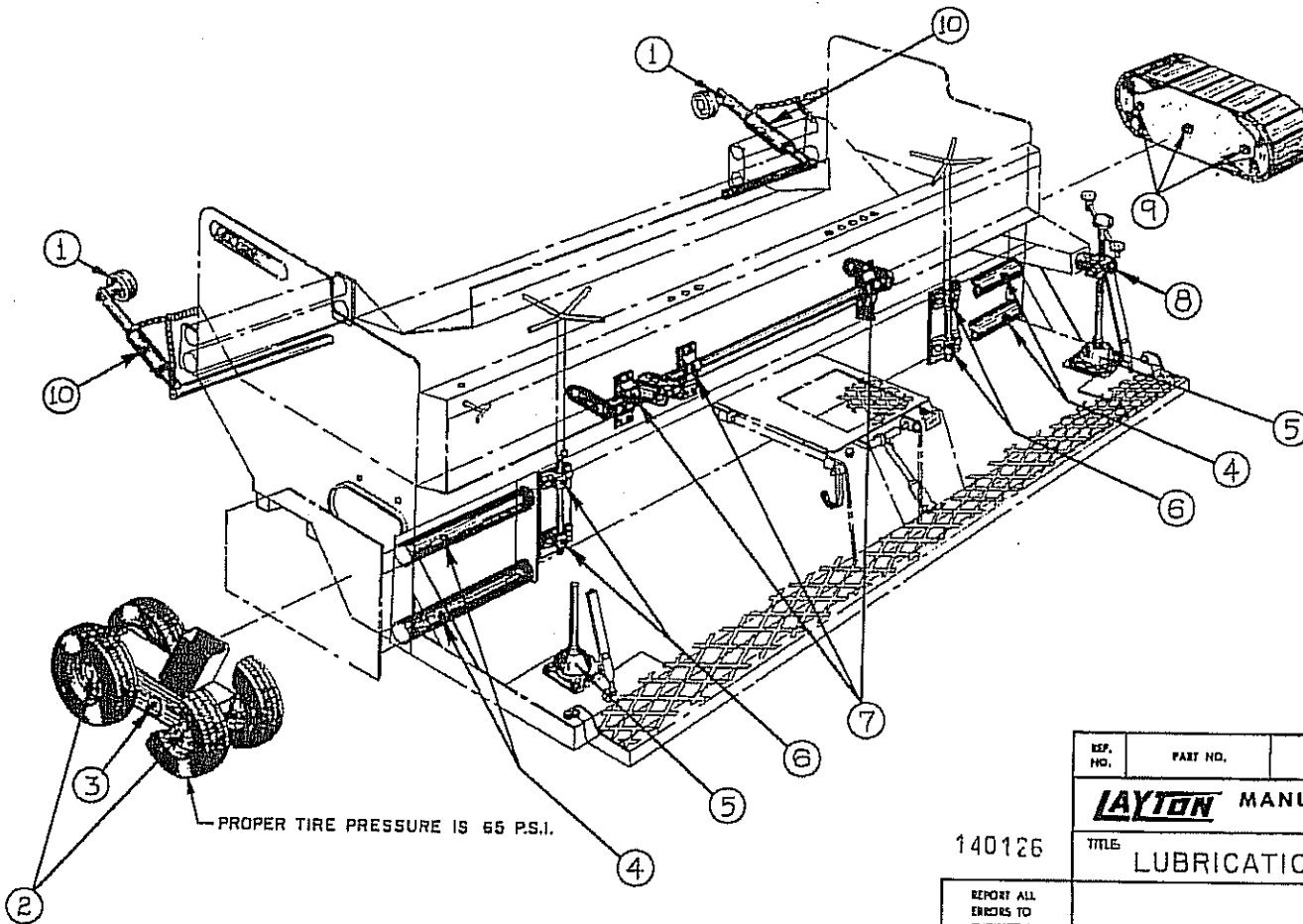

PROPER TIRE PRESSURE IS 65 P.S.I.

SVC

PAGE H-1

140126

REF. NO.	PART NO.	DESCRIPTION	HD. NO.	DWG. NO.
		LAYTON MANUFACTURING COMPANY SALEM, OREGON	DRAWN BY <i>John P. Wilson</i>	
		TITLE LUBRICATION POSITIONS	DATE 6-25-73	
		SCALE NONE	CHECKED BY <i>[Signature]</i>	
		REPORT ALL ERRORS TO ENGINEERING DEPARTMENT	ENGINEERING APPROVED	
		DO NOT SCALE DRAWINGS	PRODUCTION APPROVED	
		PRODUCT PAVER 500	BILL OF MATERIALS	
		PART NO.	LAYOUT PEG.	
			DRAWING NO. C-113	