

32	500-523	BEARING ADJUST NUT	1	D-1268
31	500-524	NEEDLE THRUST BEARING RACE .126	4	
30	500-362	HAIR PIN 1/8 DIA. X 2 1/2" LG.	1	
29	325	HITCH ARM LINKAGE	1	D-304
28	550-139	RIM ROLL - POLY COVERED	2	
27	500-530	HITCH-ARM WLDMT.(HEAVY DUTY)	1	D-1264
26	500-531	FRONT SPACER (SIDE ROLL) R.H.	1	D-1262

25	500-190	COTTER PIN 1/8 DIA. X 1" LG.	1	
24	500-189	STD. FLAT WASHER 1/2	1	
23	327	CLEVIS PIN 1/2 DIA. X 1 3/4" LG.	2	
22	500-404	HITCH ARM CLEVIS FASTENER	1	
21	321	HITCH ARM CLEVIS CASTING	1	D-979
20	500-207	SOCKET SETSCREW 1/4-20 X 1/4 LG.	2	
19	500-530	HITCH-ARM-HEAVY DUTY	1	D-1265
18	500-320	GREASE FITTING 1/4-28 MF (STR.)	1	
17	500-513	HITCH-ARM SIDE ROLL W/ BUSHINGS	1	D-1263
16	500-514	SIDE ROLL BUSHING	2	
15	500-515	NEEDLE THRUST BEARING	2	
14	339	HEX HD. CPSW. 3/8-16 NC X 3" LG.	1	
13	500-003	HEX HD. CPSW. 3/8-16 NC X 3/4" LG.	1	
12	500-516	FRONT SPACER (SIDE ROLL) L.H.	1	D-1277
11	500-056	STD. LOCKWASHER 3/8	2	
10	500-012	HEX NUT 3/8-16 NC	2	
9	338	HEX NUT 1-B NC	1	
8	337	STD. LOCKWASHER 1"	1	
7	344	HITCH-ARM RETAINING CHAIN	1	D-899
6	500-518	SPINDLE SUPPORT	1	D-1267
5	500-176	GREASE FITTING 1/8 (STR.)	1	
4	500-519	RIM ROLL (HEAVY DUTY)	1	D-1266
3	400-278	RIM ROLL BEARING CUP AND CONE	2	
2	500-521	RIM ROLL ADJUST NUT SEAL	1	D-1267
1	500-522	RIM ROLL SPINDLE	1	D-1267

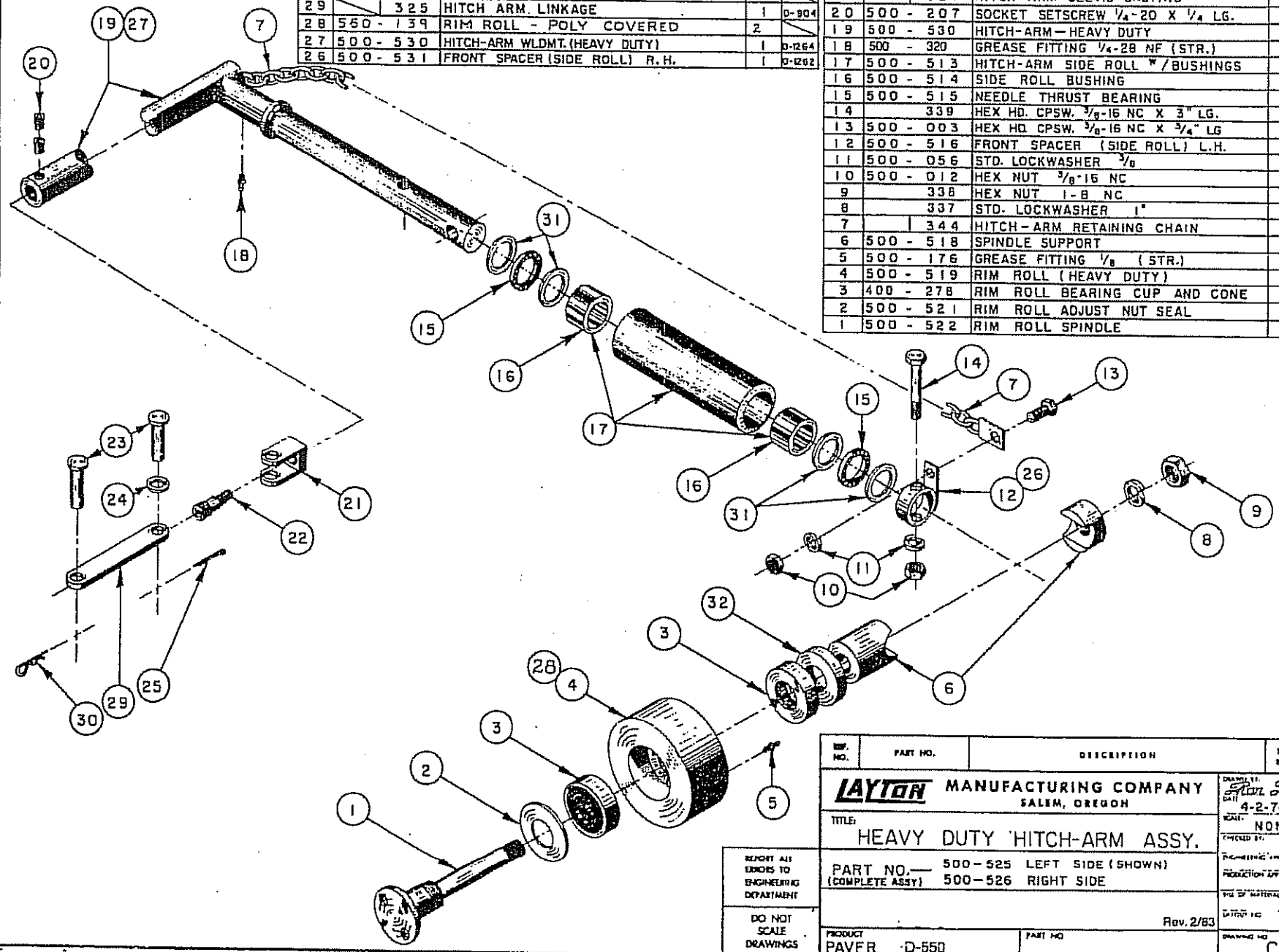

REPORT ALL ERRORS TO ENGINEERING DEPARTMENT

DO NOT SCALE DRAWINGS

REF. NO.	PART NO.	DESCRIPTION	NO. REQ.	DWG. NO.
<b>LAYTON MANUFACTURING COMPANY</b> SALEM, OREGON				
TITLE: <b>HEAVY DUTY HITCH-ARM ASSY.</b>			DRAWN BY: <i>John Phelps</i>	
PART NO.— 500-525 LEFT SIDE (SHOWN) (COMPLETE ASSY) 500-526 RIGHT SIDE			DATE: 4-2-74	
Rev. 2/83			SCALE: NONE	
PRODUCT PAVER D-650			CHECKED BY: [Signature]	
PART NO			DESIGNED BY: [Signature]	
DRAWING NO C-220			PRODUCTION APPROVED: [Signature]	